

Kit valige rigide laterali - 96781551AA**Rigid side pannier kit - 96781551AA****Simbologia**

Per una lettura rapida e razionale sono stati impiegati simboli che evidenziano situazioni di massima attenzione, consigli pratici o semplici informazioni. Prestare molta attenzione al significato dei simboli, in quanto la loro funzione è quella di non dovere ripetere concetti tecnici o avvertenze di sicurezza. Sono da considerare, quindi, dei veri e propri "promemoria". Consultare questa pagina ogni volta che sorgeranno dubbi sul loro significato.

**Attenzione**

La non osservanza delle istruzioni riportate può creare una situazione di pericolo e causare gravi lesioni personali e anche la morte.

**Importante**

Indica la possibilità di arrecare danno al veicolo e/o ai suoi componenti se le istruzioni riportate non vengono eseguite.

**Note**

Fornisce utili informazioni sull'operazione in corso.

Riferimenti

I particolari evidenziati in grigio e riferimento numerico (Es. ①) rappresentano l'accessorio da installare e gli eventuali componenti di montaggio forniti a kit.

I particolari con riferimento alfabetico (Es. Ⓐ) rappresentano i componenti originali presenti sul motoveicolo.

Tutte le indicazioni destro o sinistro si riferiscono al senso di marcia del motociclo.

Avvertenze generali**Attenzione**

Le operazioni riportate nelle pagine seguenti devono essere eseguite da un tecnico specializzato o da un'officina autorizzata Ducati.

**Attenzione**

Le operazioni riportate nelle pagine seguenti se non eseguite a regola d'arte possono pregiudicare la sicurezza del pilota.

**Note**

Documentazione necessaria per eseguire il montaggio del Kit è il Manuale Officina, relativo al modello di moto in vostro possesso.

**Note**

Nel caso fosse necessaria la sostituzione di un componente del kit consultare la tavola ricambi allegata.

Symbols

The symbols used in this manual are aimed at making reading direct and easy. The symbols are used either to draw the reader's attention on potentially hazardous conditions, or to give practical advice or to supply general information. Pay the utmost attention to these symbols as they are used to remind of technical principles or safety measures which will not be repeated extensively. They must therefore be considered as "reminders". Check with this page in case of doubt about their meaning.

**Warning**

Failure to comply with these instructions may put you at risk and lead to severe injury or death.

**Important**

It indicates the possibility of damaging the motorcycle and/or its components if the instructions are not followed.

**Notes**

It supplies useful information about the operation in progress.

References

The parts highlighted in grey and with a reference number (e.g. ①) represent the accessory to be installed and any assembly components supplied with the kit.

The parts with alphabetic reference (e.g. Ⓐ) represent the original components present on the motorcycle.

All left and right indications are referred to the motorcycle direction of travel (forward riding position).

General notes**Warning**

The operations listed in the following pages must be carried out by a specialised technician or by a Ducati authorised service centre.

**Warning**

Carefully perform the operations on the following pages since they might negatively affect rider safety.

**Notes**

The Workshop Manual of your motorcycle model is the documentation required to assemble the Kit.

**Notes**

Should it be necessary to change any kit parts, please refer to the attached spare part table.

**Warning**

Operating, servicing and maintaining a passenger vehicle or off-highway motor vehicle can expose you to chemicals including engine exhaust, carbon monoxide, phthalates, and lead, which are known to the State of California to cause cancer and birth defects or other reproductive harm. To minimize exposure, avoid breathing exhaust, do not idle the engine except as necessary, service your vehicle in a well-ventilated area and wear gloves or wash your hands frequently when servicing your vehicle. For more information go to www.P65Warnings.ca.gov/passenger-vehicle.

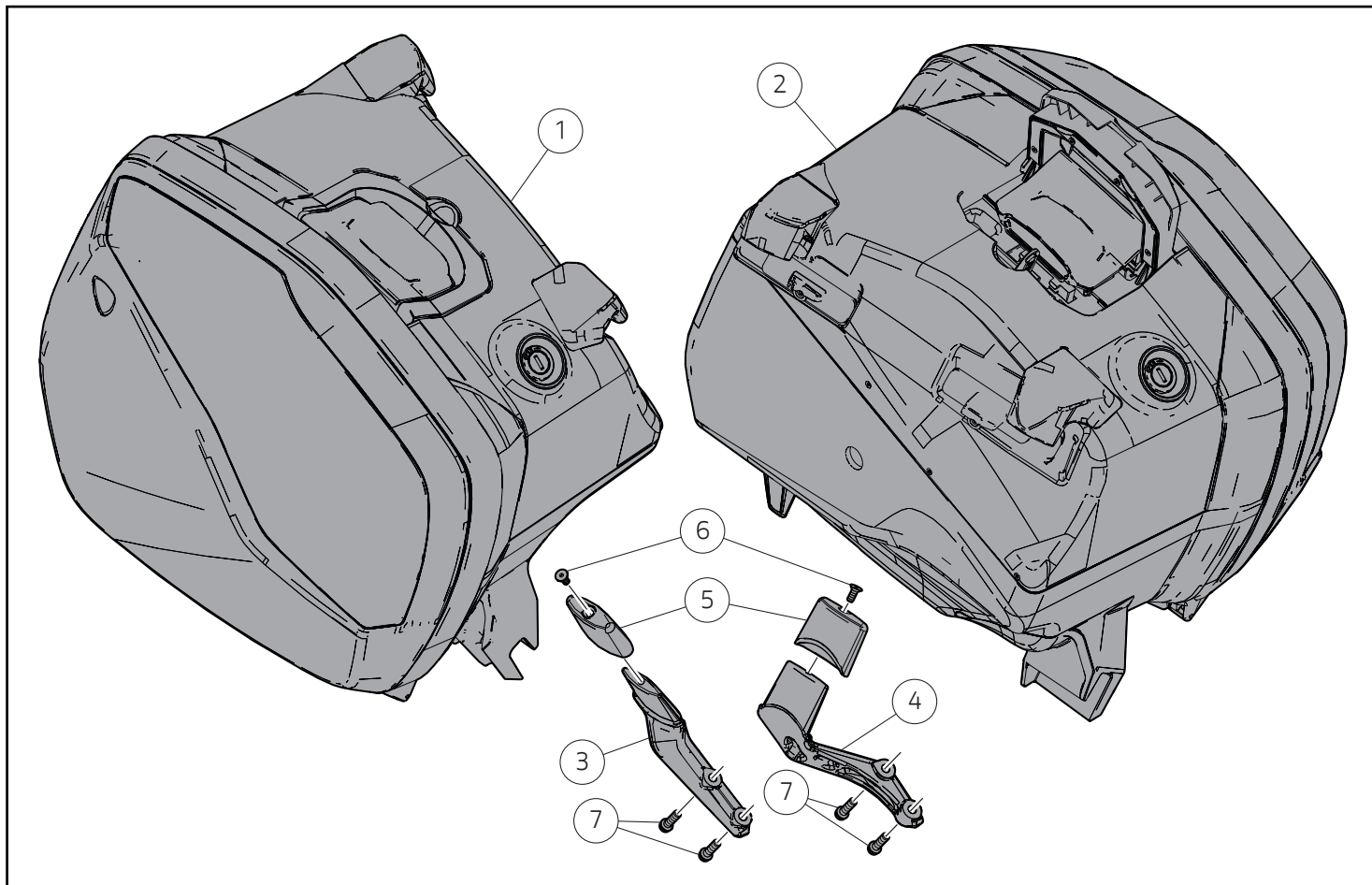

Importante

I componenti del kit possono essere soggetti ad aggiornamenti; consultare il DCS (Dealer Communication System) per avere informazioni sempre aggiornate.

Importante

Questo kit è da abbinare ad un set di cover disponibili in varie colorazioni. Consultare il DCS (Dealer Communication System) per scegliere tra le colorazioni disponibili.

Important

The parts of the kit can be updated; for information always up to date, please refer to DCS (Dealer Communication System).

Important

This kit is to be combined with a set of covers available in various colours. Consult the DCS (Dealer Communication System) to choose among the available colours.

Pos.	Denominazione	Name
1	Borsa destra	RH side pannier
2	Borsa sinistra	LH side pannier
3	Staffa destra	RH bracket
4	Staffa sinistra	LH bracket
5	Rivestimento staffa	Bracket cover
6	Vite TSPEI M5x12	TSPEI screw M5x12
7	Vite TCEIF M6x20	TCEIF screw M6x20

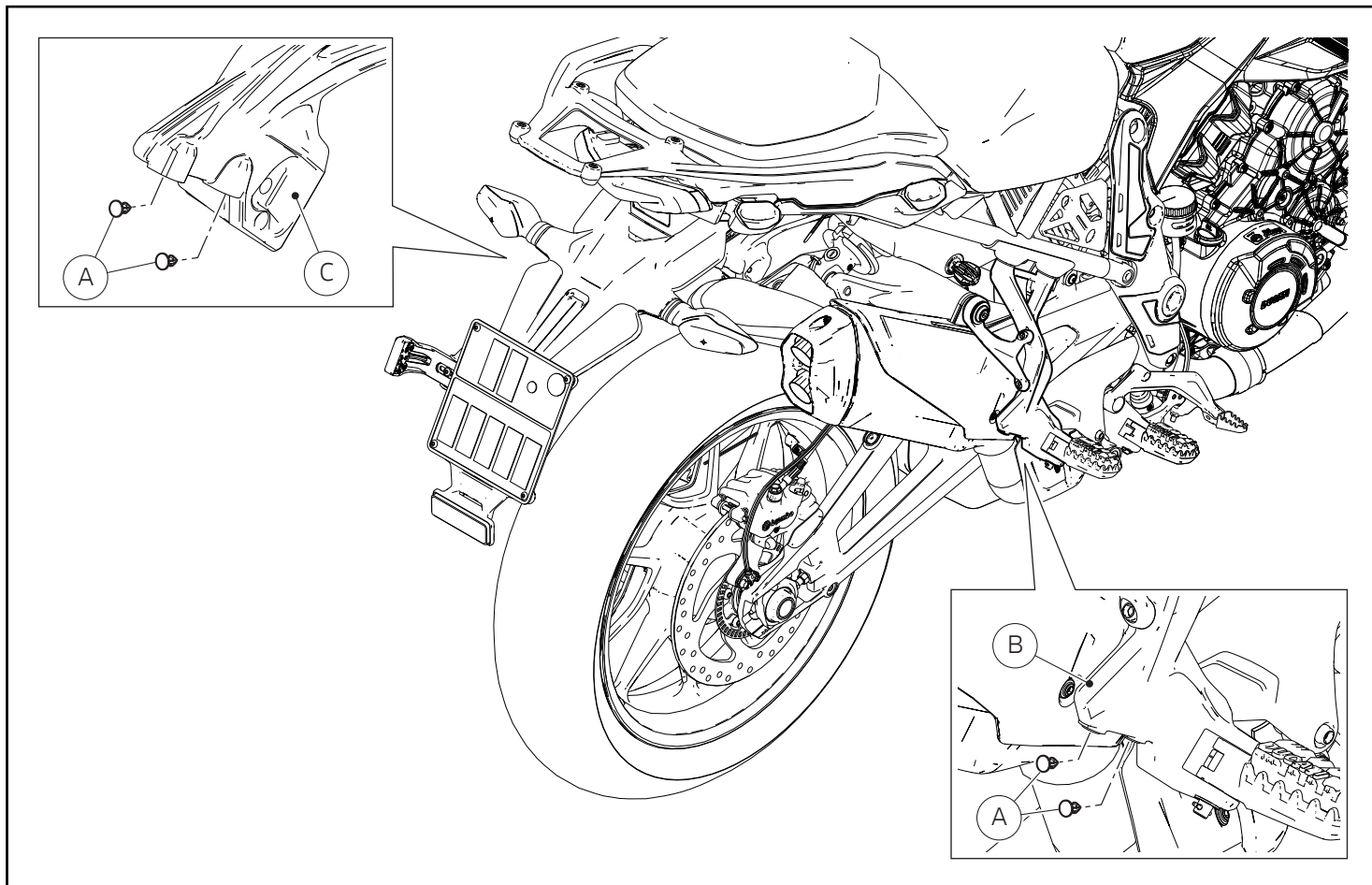

Smontaggio componenti originali

Rimuovere i tappi originali (A) dalle piastre portapedana (B) e (C).

Removing the original components

Remove the original caps (A) from footpeg holder plates (B) and (C).

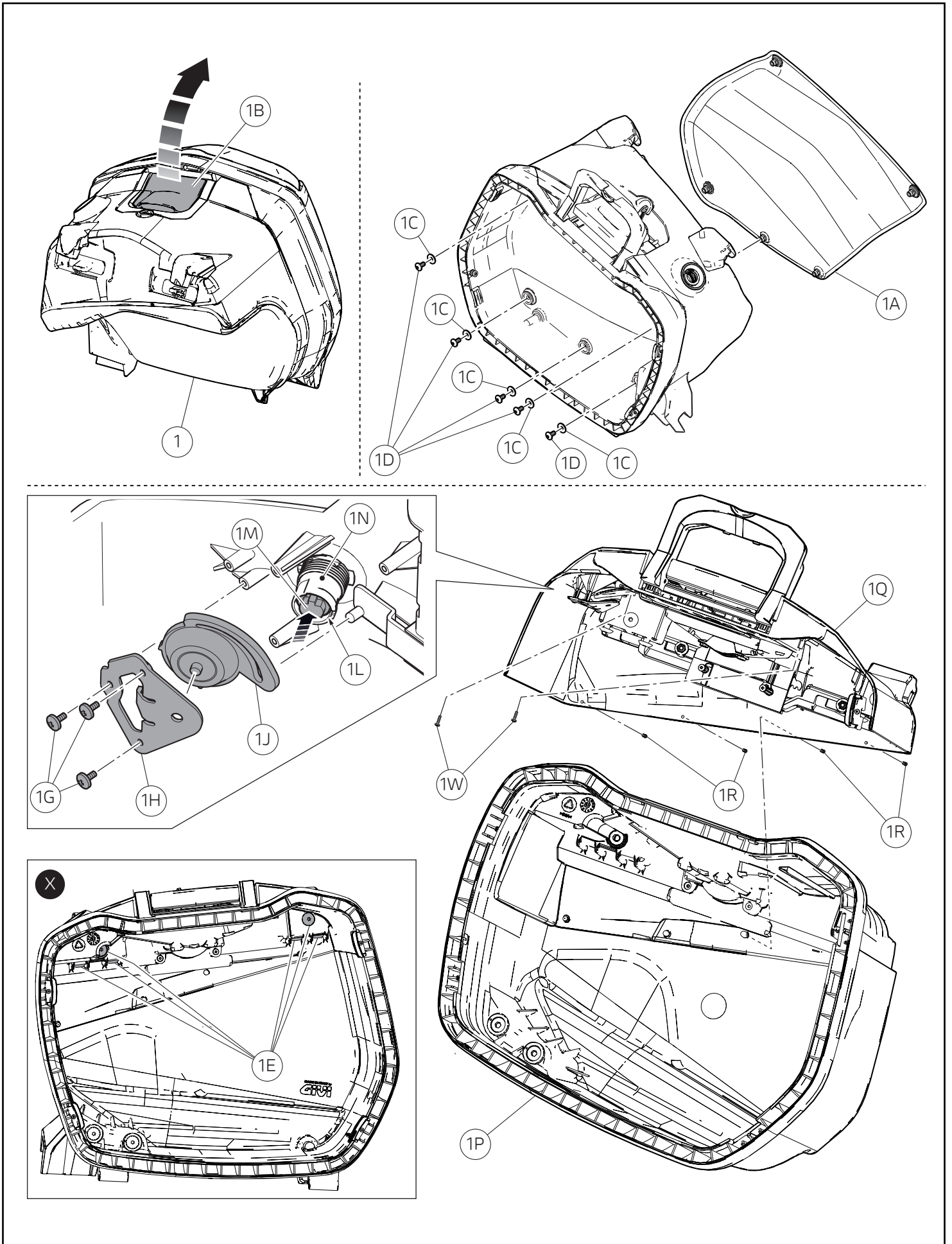

Montaggio componenti kit



Importante

Verificare, prima del montaggio, che tutti i componenti risultino puliti e in perfetto stato. Adottare tutte le precauzioni necessarie per evitare di danneggiare qualsiasi parte nella quale ci si trova ad operare.



Note

Vengono prese come esempio le operazioni da effettuare sulla valigia destra (1). Le operazioni di rimozioni paracalore (1A) sono da considerarsi solo per la valigia destra (1). Le restanti procedure sono le stesse per entrambe le valige.

Agire sulla maniglia (1B) e aprire la valigia (1). Dall'interno rimuovere e conservare le n.5 viti (1D) complete di rondelle (1C).

Dall'interno, rimuovere e conservare le n.6 viti (1E), come mostrato nel riquadro (X). Sempre dal lato interno, rimuovere e conservare le n.2 viti (1W). Operando dal lato esterno della valigia (1), rimuovere e conservare le n.4 viti (1R), e svincolare la calotta superiore (1Q) dal fondo borsa (1P). Svitare le n.3 viti (1G), rimuovere la piastra di fissaggio (1H) e la piastra sottoserratura (1J). Recuperare le n.3 viti (1G). Spostare la lamella di trattenimento (1L) e rimuovere simultaneamente il nottolino serratura originale (1M) dal blocco serratura (1N) sfilandolo verso l'esterno.

Assembling the kit components



Important

Before assembling, check that all parts are clean and in good conditions. Adopt all necessary precautions to avoid damaging any part you are working on.



Notes

The operations to be carried out on the RH pannier (1) are taken as examples. The heat guard removal operations (1A) are only to be considered for the RH pannier (1). The remaining procedures are the same for both panniers.

Act on the handle (1B) and open the pannier (1). From the inside, remove and keep the 5 screws (1D) complete with washers (1C).

From the inside, remove and keep the 6 screws (1E), as shown in the box (X). Always from the inside, remove and keep the 2 screws (1W). By working from the outside of the pannier (1), remove and keep the 4 screws (1R), and detach the upper shell (1Q) from the bottom of the pannier (1P). Loosen the no. 3 screws (1G), remove retaining plate (1H) and back plate (1J). Keep the no.3 screws (1G). Move the retaining reed (1L) and at the same time remove the original lock nipple (1M) from lock unit (1N) sliding it outwards.

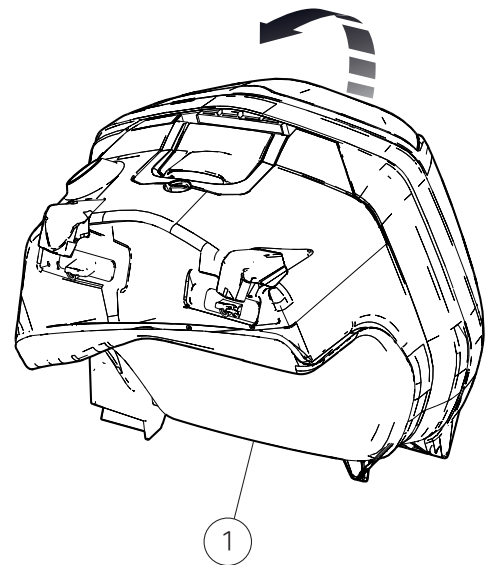
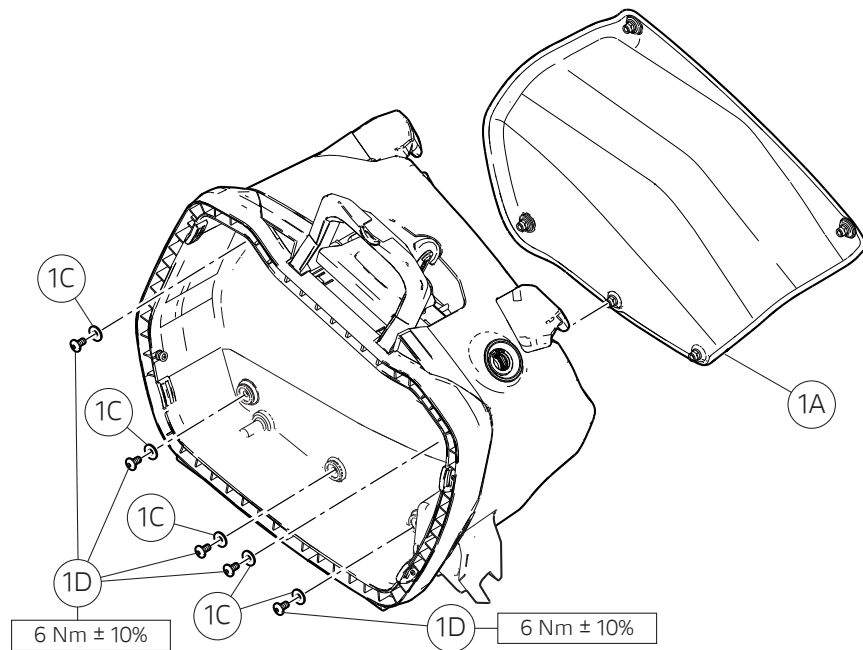
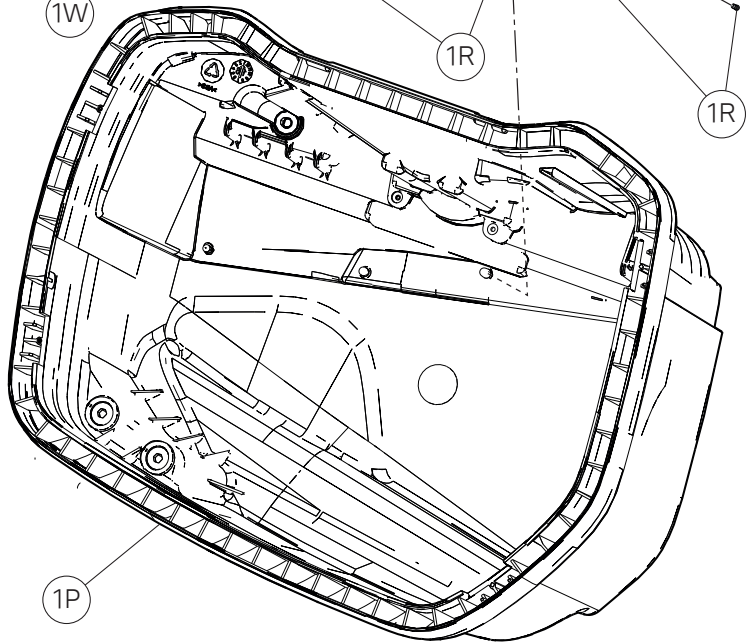
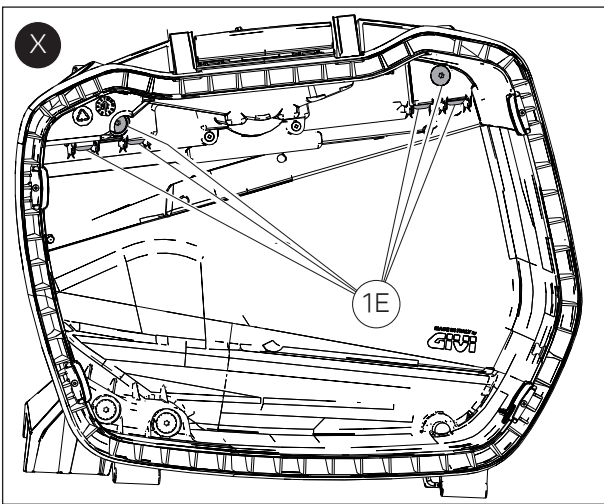
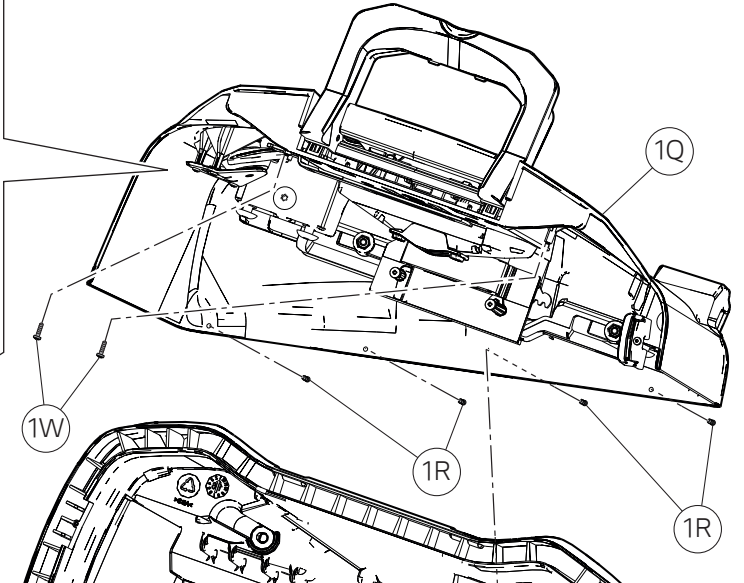
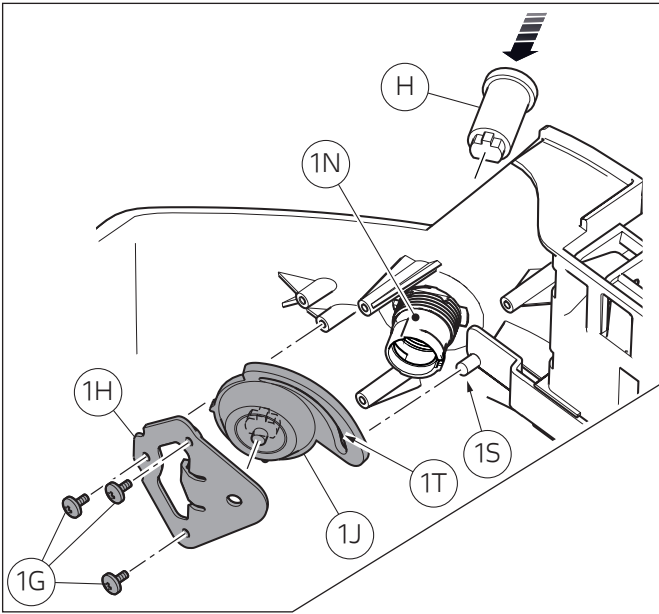

**Note**

Per comprendere meglio le operazioni da eseguire per la sostituzione della serratura, viene mostrata solo la valigia (1) senza il coprichio borsa.

Inserire il nottolino serratura (H) in dotazione con il motoveicolo all'interno del blocco serratura (1N) sino a fare scattare la linguetta di sicurezza che blocca i due pezzi tra loro. Posizionare la piastra sottoserratura (1J) sul blocco serratura (1N), facendo coincidere lo scasso presente nella parte inferiore della piastra con la tacca di riferimento presente sul nottolino (H). Verificare che il perno (1S) sia inserito nell'asola (1T). Posizionare la piastra di fissaggio (1H) e impuntare le n.3 viti originali (1G). Serrare le n.3 viti originali (1G) a mano. Verificare il corretto funzionamento del sistema serratura. Posizionare la calotta superiore (1Q) sul fondo borsa (1P). Impuntare, dal lato esterno, le n.4 viti originali (1R) e dal lato interno le n.2 viti originali (1W). Serrare le n.4 viti originali (1R) a mano. Impuntare le n.6 viti originali (1E). Serrare le n.6 viti originali (1E) a mano.

**Note**

Solo per la valigia destra, occorre ripristinare il paracalore (1A).

Posizionare il paracalore (1A) nella sua sede originale e, dall'interno della valigia (1), impuntare le n.5 viti originali (1D) precedute dalle n.5 rondelle originali (1C). Serrare le n.5 viti (1D) alla coppia indicata.

Richiudere la valigia.

**Notes**

In order to better understand the operations to be carried out for lock replacement, only pannier (1) is shown without the bag cover.

Fit the supplied lock nipple (H) inside lock unit (1N) until the safety tab locking the two parts clicks in place. Position back plate (1J) on lock unit (1N), matching the recess present on the lower side of plate with the reference mark available on nipple (H). Ensure that pin (1S) is fitted inside slot (1T). Position the retaining plate (1H) and start the no. 3 original screws (1G). Tighten the no. 3 original screws (1G) by hand. Make sure that lock system works properly. Position the upper shell (1Q) on the bottom of the pannier (1P). From the outer side, start the no. 4 original screws (1R) and from the internal side the no. 2 original screws (1W). Tighten the no. 4 original screws (1R) by hand. Start no.6 original screws (1E). Tighten the no. 6 original screws (1E) by hand.

**Notes**

For the RH pannier only, the heat guard (1A) must be replaced.

Position the heat guard (1A) in its original position and, from inside the pannier (1), tighten the 5 original screws (1D) with the 5 original washers (1C). Tighten the no.5 screws (1D) to the specified torque.

Close the pannier.

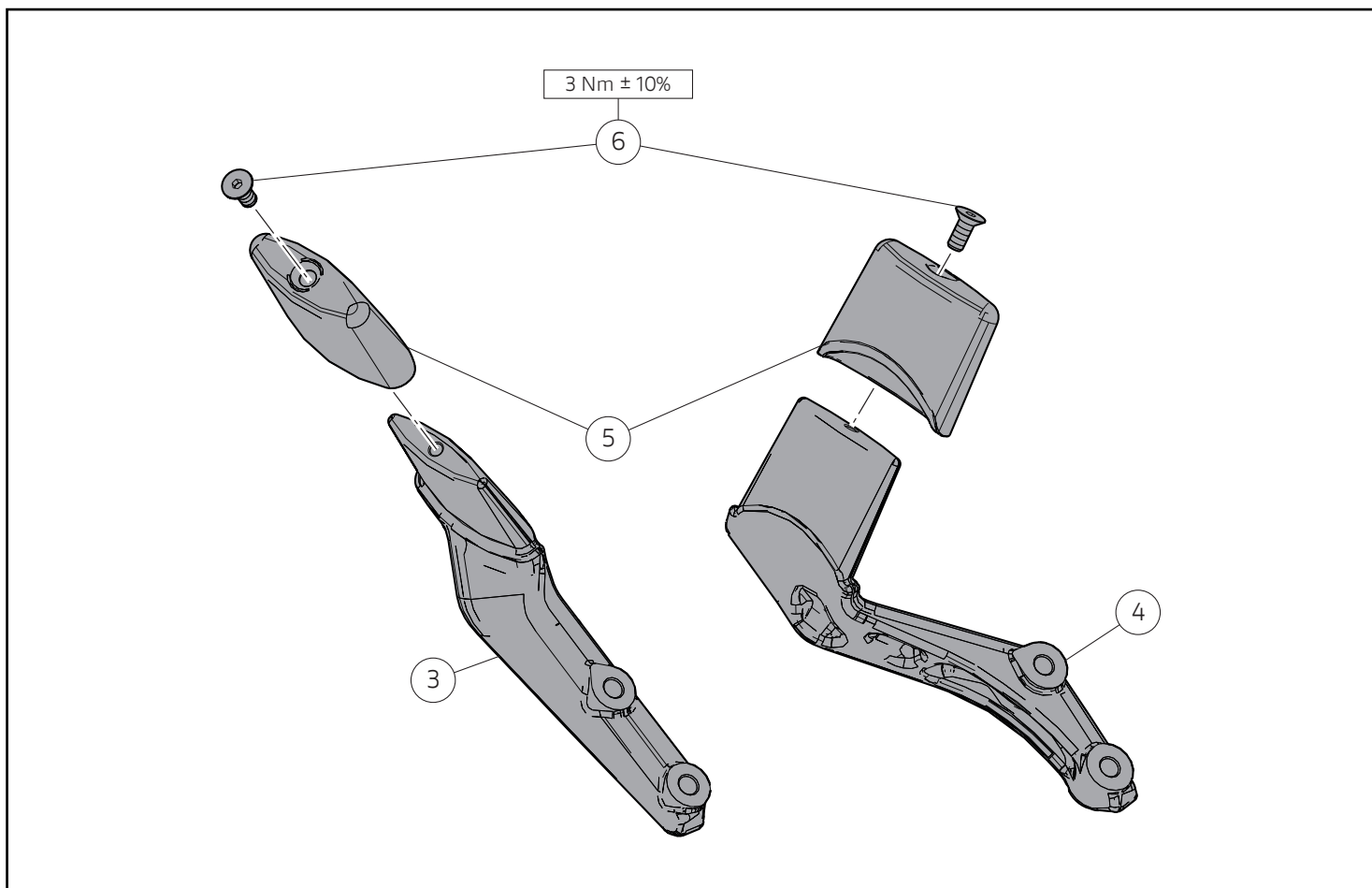

Premontaggio staffe laterali

Calzare il rivestimento staffa (5) sulla staffa destra (3) e sulla staffa sinistra (4). Impuntare le n.2 viti (6). Serrare le n.2 viti (6) alla coppia indicata.

Side bracket pre-assembly

Fit the bracket cover (5) on the RH bracket (3) and on the LH bracket (4). Start no. 2 screws (6). Tighten no.2 screws (6) to the specified torque.

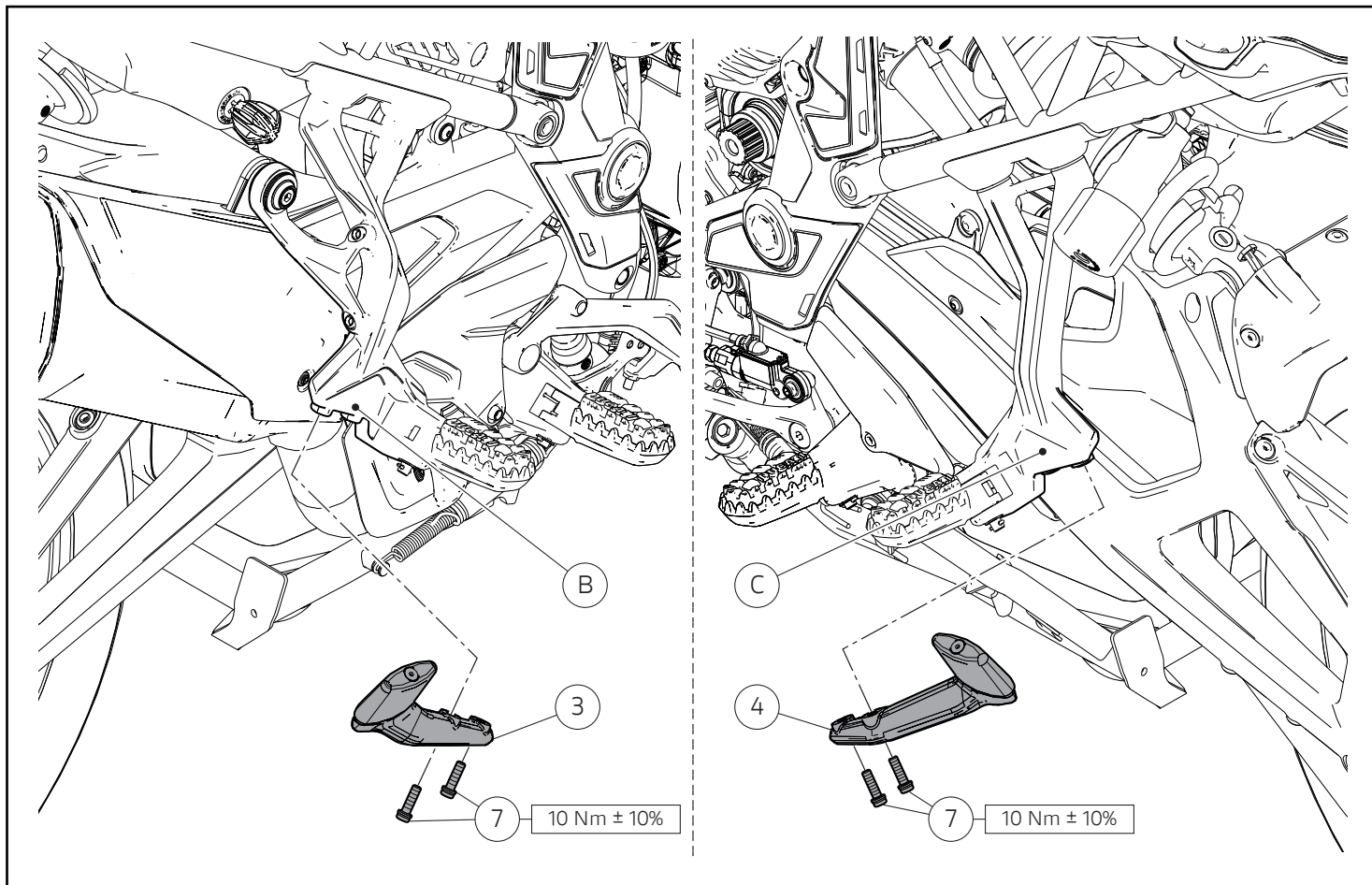

Montaggio staffe laterali

Posizionare la staffa destra (3) sulla piastra portapedana (B) e impuntare le n.2 viti (7). Serrare alla coppia indicata. Posizionare la staffa sinistra (6) sulla piastra portapedana (C) e impuntare le n.2 viti (7). Serrare alla coppia indicata.

Side bracket assembly

Position the right-hand bracket (3) on the footpeg holder plate (B) and start the no. 2 screws (7). Tighten to the specified torque. Position the left-hand bracket (6) on the footpeg holder plate (C) and start the no. 2 screws (7). Tighten to the specified torque.

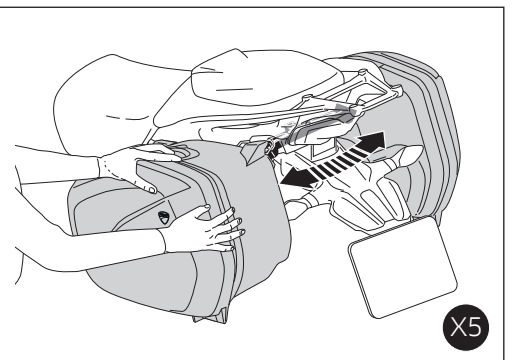
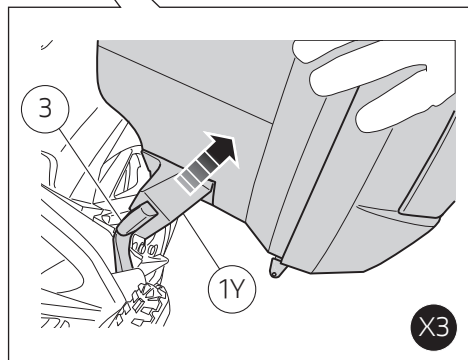
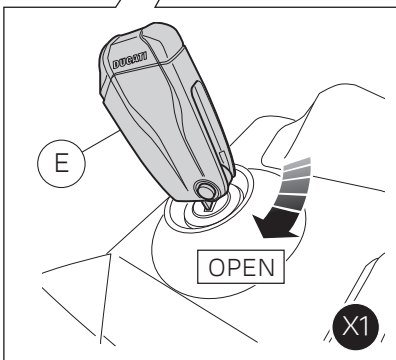
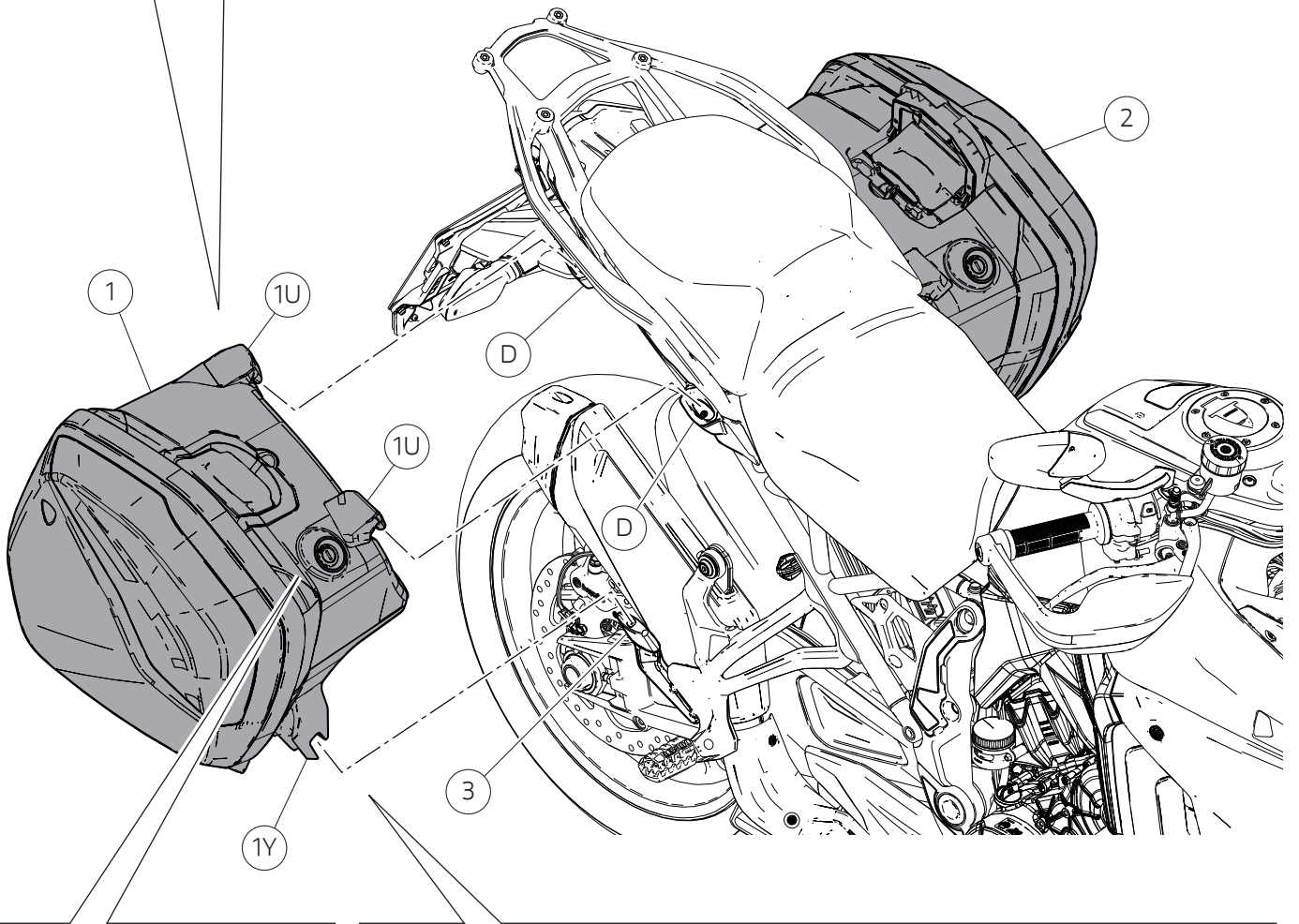
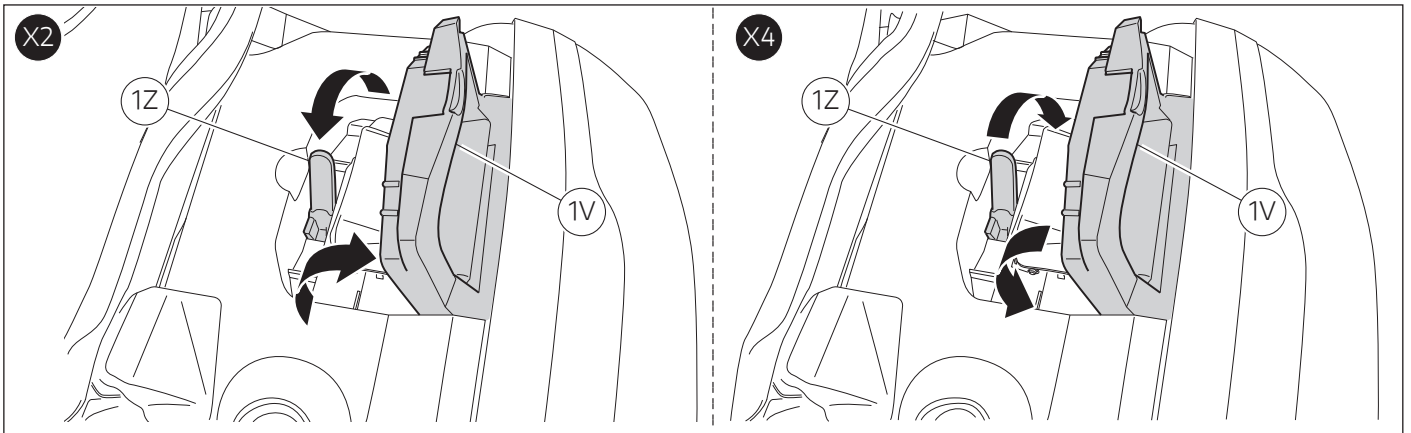

Montaggio valige laterali

Posizionare la chiave (E) nella serratura e ruotare in senso orario. Aprire la maniglia (1V) e sollevare la leva (1Z) verso la parte anteriore, in posizione perpendicolare alla valigia.

Posizionare la borsa laterale inserendo i ganci superiori (1U) nelle relative sedi (D).



Note

Posizionare prima il gancio anteriore e successivamente quello posteriore.

Verificare il corretto posizionamento della valigia destra (1) sul supporto inferiore (3).

Abbassare completamente la leva (1Z) verso il lato posteriore. Chiudere la maniglia (1V) e ruotare la chiave (E) in senso antiorario per il bloccaggio della valigia. Estrarre la chiave.



Importante

Accertarsi dell'avvenuto e corretto aggancio, tirando lateralmente la borsa con moderazione e verificando anche il movimento basculante.

Operare allo stesso modo per il montaggio della valigia laterale sinistra (2).

Rimozione valige laterali

Per rimuovere la valigia laterale destra (1), posizionare la chiave (E) nella serratura e ruotarla in senso orario. Aprire la maniglia (1V). Sollevare la leva (1Z) verso la parte anteriore, in posizione perpendicolare alla valigia. Sostenere la valigia (1) dalla maniglia (1V). Estrarre la valigia (1) dalle sedi (D), sfilando prima gancio (1U) posteriore e poi l'anteriore, e scalzare la valigia dal supporto inferiore (3).

Operare allo stesso modo per l'estrazione della valigia laterale sinistra (2).



Note

E' possibile acquistare presso un concessionario/dealer autorizzato il Kit "Set Borse interne per valigie laterali".

Side pannier assembly

Insert the key (E) in the lock and turn it clockwise. Open the handle (1V) and lift the lever (1Z) towards the front side until it is perpendicular to the pannier.

Position the side pannier by inserting the upper hooks (1U) in their respective seats (D).



Notes

First position the front hook and then the rear hook.

Check that the RH pannier (1) is correctly positioned on the lower support (3).

Lower the lever (1Z) completely towards the rear. Close the handle (1V) and turn the key (E) anticlockwise to lock the pannier. Remove the key.



Important

Make sure that the pannier is properly fixed by pulling it sideways carefully and checking also its tilting movement.

Proceed in the same way to install the LH pannier (2).

Side pannier removal

To remove the RH pannier (1), place the key (E) in the lock and turn it clockwise. Open the handle (1V). Lift the lever (Z) towards the front side until it is perpendicular to the pannier. Support the pannier (1) by the handle (1V). Pull the pannier (1) out of the seats (D), first pulling out the rear hook (1U) and then the front one, and remove the pannier from the lower support. (3).

Proceed in the same way to take out the LH pannier (2).



Notes

The "Inner Bag Set for Side Panniers" Kit can be purchased at an authorised dealer.

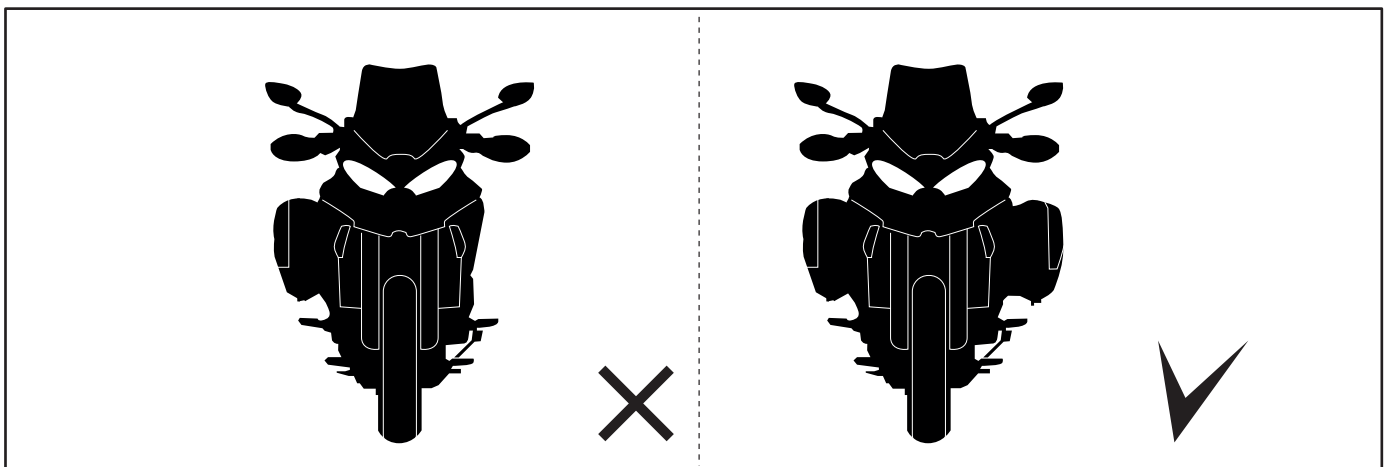
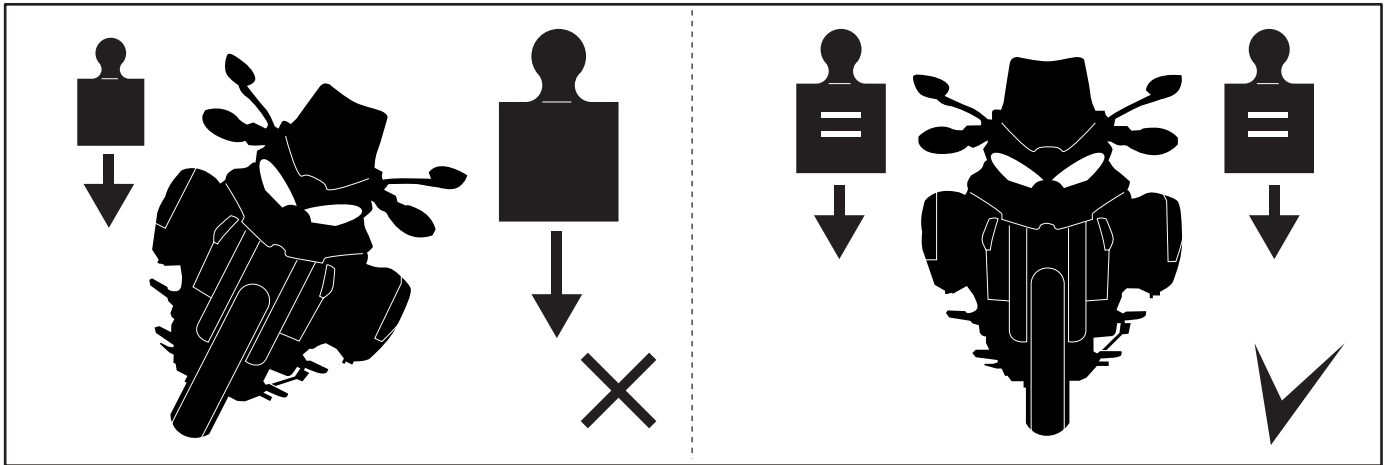
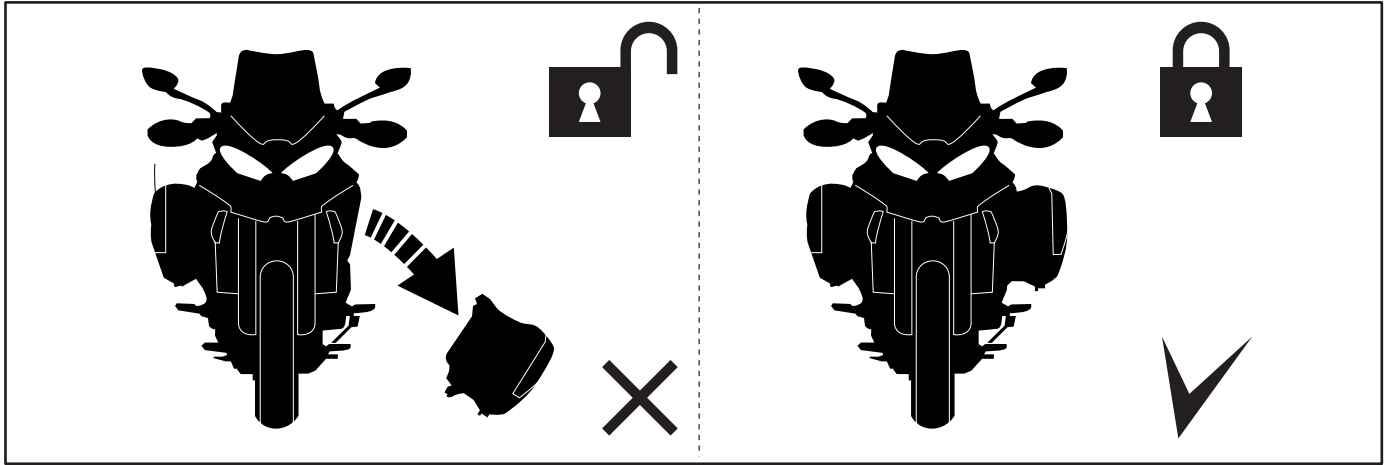

**Attenzione**

Assicurarsi sempre del corretto montaggio e serraggio delle borse sul veicolo.

**Attenzione**

Assicurarsi che il peso delle borse sia equamente distribuito su entrambi i lati per evitare problemi di squilibri al veicolo.

**Attenzione**

Installare entrambe le borse laterali; non è ammesso il montaggio soltanto di una di esse, per motivi di sicurezza.

**Attenzione**

Non posizionare oggetti sulla sella e prestare attenzione a non ancorare strumenti di contenimento ai fissaggi delle borse/top case flottanti.

**Attenzione**

La velocità massima consentita con borse laterali e bauletto non deve superare i 180 Km/h (112 mph) e comunque dovrà essere nel rispetto dei limiti di legge.

**Attenzione**

Pulire le borse laterali con uno straccio morbido e pulito utilizzando acqua tiepida e sapone. Evitare l'uso di agenti aggressivi o attrezzi ruvidi.

**Importante**

La continua e prolungata esposizione agli agenti atmosferici potrebbe determinare dei minimi o sensibili cambiamenti nel colore dei tessuti/ materiali.

**Attenzione**

Il peso massimo trasportabile dalle borse laterali è di 10 Kg (22 lb). Nel caso si ecceda il peso consigliato si rischia la rottura delle borse stesse. Questo può influire negativamente sulla sicurezza del pilota.

Quando si effettua il lavaggio della moto è necessario rimuovere le borse laterali.

**Warning**

Always ensure that the panniers are correctly fitted and tightened on the vehicle.

**Warning**

Ensure that the weight of the bags is evenly distributed on both sides to avoid problems of vehicle imbalance.

**Warning**

Install both side bags; for safety reasons, it is not permitted to install only one of them.

**Warning**

Do not place any objects on the seat and be careful not to attach floating restraining devices to the bag/top case mounts.

**Warning**

The maximum speed allowed with the side panniers and the top case fitted to the bike must not exceed 180 Km/h (112 mph) and within the limits set by the law.

**Warning**

Clean the side panniers with a soft and clean cloth using lukewarm water and soap. Avoid using aggressive substances or rough tools.

**Important**

Continuous and prolonged exposure to the elements could result in minor or significant changes in the colour of the fabrics/materials.

**Warning**

Side pannier max. loading capacity is 10 Kg (22 lb). Should this weight be exceeded, panniers could break. This can affect rider's safety.

When washing the bike, always remove side panniers.

レース専用部品 ご注文書

ご注文商品

1	P/N	商品名
2	P/N	商品名
3	P/N	商品名
4	P/N	商品名
5	P/N	商品名

お客様ご記入欄

私は上記レース専用部品を下記車両に装着し、サーキット走行のみに利用し、一般公道には利用しません。

車台番号 ZDM モデル名

お客様署名 ご注文日

ドゥカティ正規ネットワーク店記入欄

お客様に上記レース専用部品を販売し、レース専用部品のご利用方法を説明いたしました。

販売店署名 販売日 年 月 日

販売店様へお願い

- 上記ご記入の上、弊社アフターセールス部までFAXしてください。FAX : 03 - 6692 - 1317
- 取り付け車両 1台に 1枚でご使用ください。

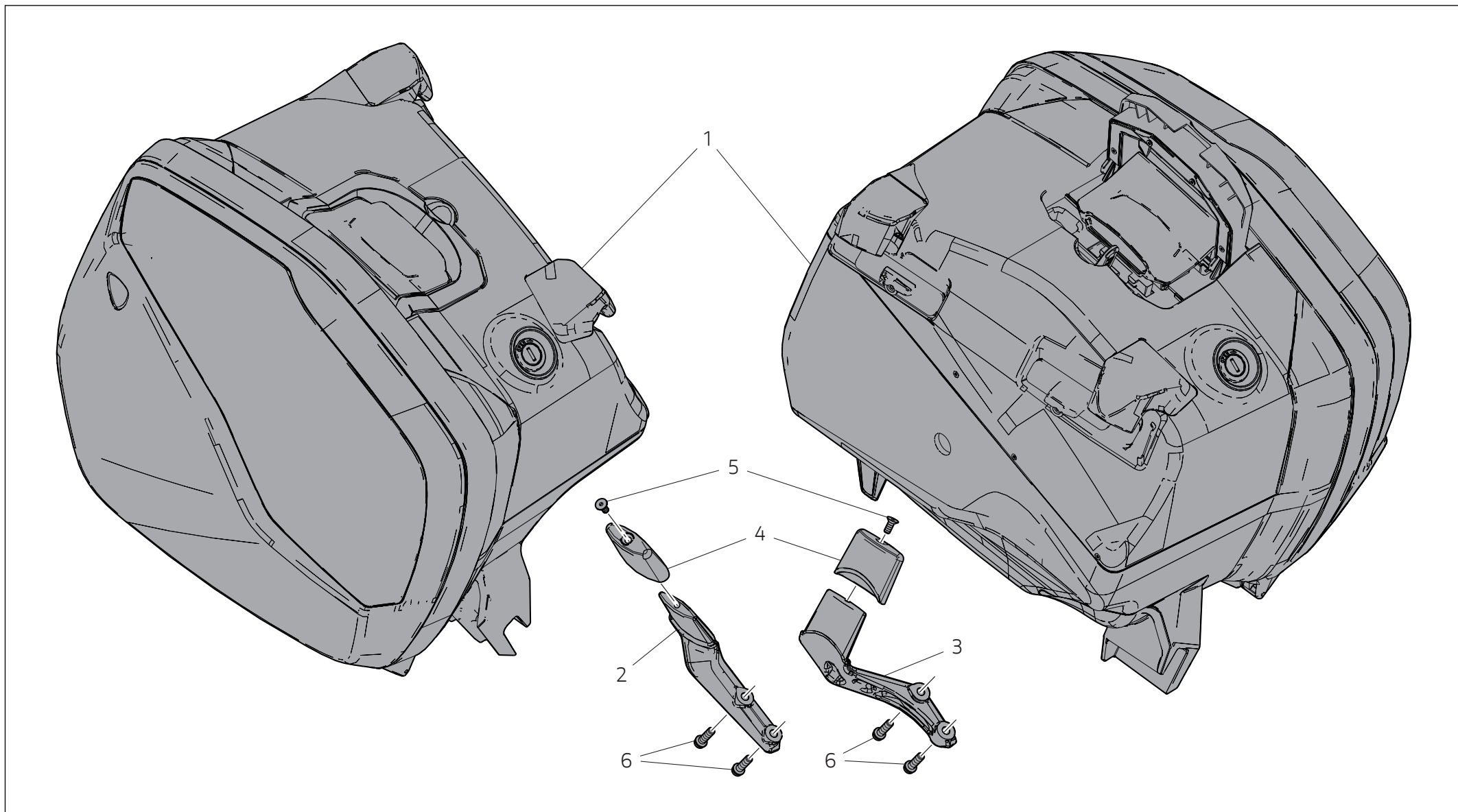

Pos.	Cod.	Denominazione	Name	Dénomination	Bezeichnung	Denominação	Denominación	名称	Q.ty
1	96781551AA	Set borse laterali	Side pannier set	Jeu de valises latérales	Set Seitenkoffer	Jogo de bolsas laterais	Set bolsas laterales	サイドバッグセット	1
2	8301H971AA	Supporto inferiore destro	RH lower support	Support inférieur droit	Rechter unterer Halter	Suporte inferior direito	Soporte inferior derecho	右ロアマウント	1
3	8301H981AA	Supporto inferiore sinistro	LH lower support	Support inférieur gauche	Linker unterer Halter	Suporte inferior esquerdo	Soporte inferior izquierdo	左ロアマウント	1
4	76414561A	Rivestimento supporto	Support cover	Revêtement support	Halterverkleidung	Revestimento do suporte	Revestimiento soporte	マウントカバー	2
5	77750343B	Vite TSPEI M5x12	TSPEI screw M5x12	Vis TFPHC M5x12	Senkkopf-Innensechskantschraube M5x12	Parafuso de cabeça escareada chata com sextavado interno M5x12	Tornillo TSPEI M5x12	スクリュー TSPEI M5x12	2
6	77156678B	Vite TCEIF M6x20	TCEIF screw M6x20	Vis TCHC M6x20	Zylinderschraube mit Innensechskant und Flansch M6x20	Parafuso de cabeça cilíndrica flangeada com sextavado interno M6x20	Tornillo TCEIF M6x20	スクリュー TCEIF M6x20	4